

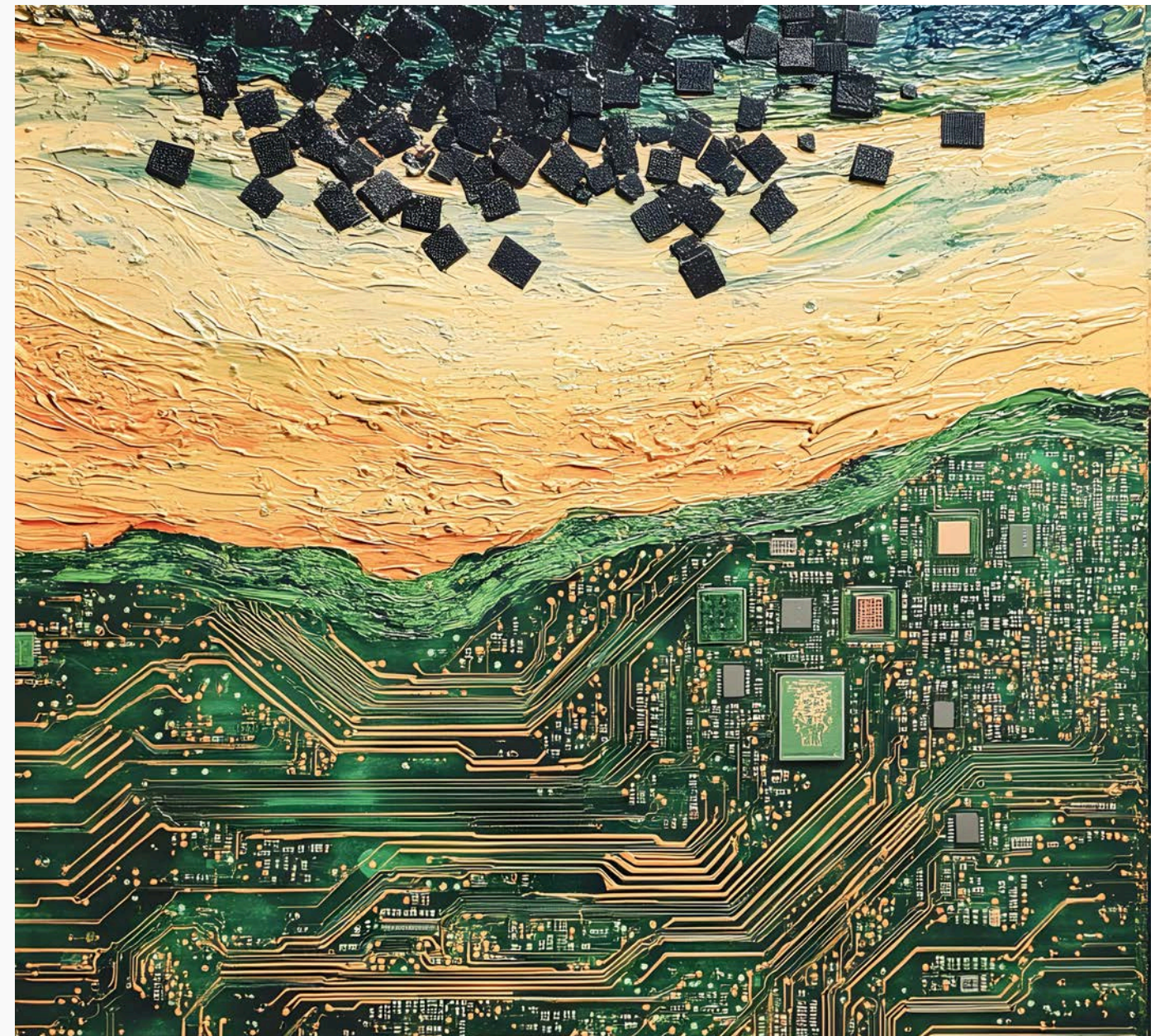

Carbon Solutions

For
High Temperature Industries

Semiconductor, Photovoltaics & Furnaces



AYD ADVANCED MATERIALS

01/ PAGE

About Us

03/ PAGE

Product Features

08/ PAGE

Manufacturing Process

12/ PAGE

Soft Felt

02/ PAGE

Our Values

06/ PAGE

Product Matrix

10/ PAGE

Rigid Insulation

14/ PAGE

Packaging and Transportation



A Greener Manufacturing Process

Specializing in carbon materials for decades, we keep advancing our carbon material product line for new energy applications.

Aoyida provides thermal insulation solutions for the following industries:

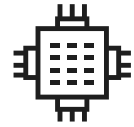

Semiconductor



Photovoltaics



Optical Fiber



Furnaces

Our thermal insulation products: CarboniteX			
Raw Material Precursor	Rayon	Pitch	
Fiber	Long Fiber	Short Fiber	
Product Types	Rigid Insulation	Soft Felt	
Heat Processing Levels	Carbonized	Graphitized	Purified

We consistently uphold the principles of green, environmentally friendly, and safe production.

From design and products to services, we provide customized hot-zone solutions.

Aoyida's carbon materials follows strict green manufacturing standards:

- Minimizes occupational health risks
- Ensures an eco-friendly production process
- Uses safe, environmentally friendly adhesives

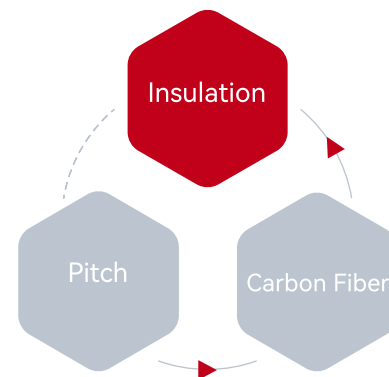

CarboniteX

Excellence & Stability

01

Superior Thermal Insulation

Through optimal product design, excellent thermal insulation performance is achieved, withstanding temperatures up to 3000°C.

02

Scientific Fiber Alignment

By adopting wet molding process, the fibers are arranged in a specified direction, further optimizing thermal insulation performance.

03

High Purity

Advanced manufacturing processes and strict process control ensure that the product meets purity requirements.

04

High Strength

AYD's product demonstrates exceptional resistance to compression and flexural stress.

05

Integrated Solutions

We provide customized hot-zone solutions.

06

Precision Machining

State-of-the-art carbon material processing ensures high precision and accuracy.

Features of CarboniteX Rigid Insulation

Oxidation Resistance

Indicates the material's reaction with oxygen, affecting its lifespan. Influenced by graphitization, surface structure, and impurities. AYD's rigid insulation demonstrates excellent oxidation resistance in the following tests.

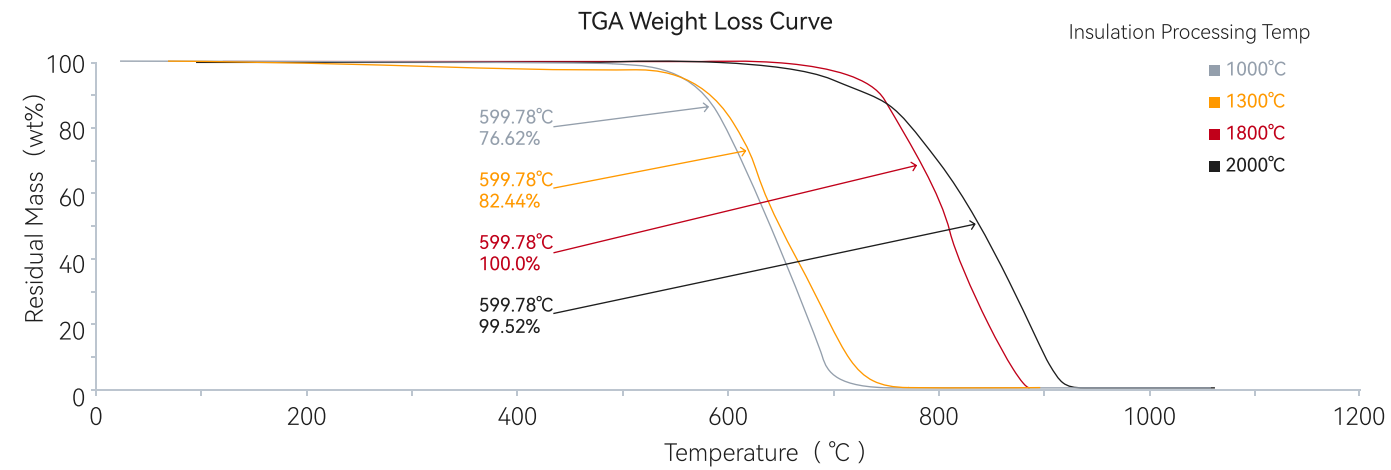

Measurement conditions: Room temperature to 1000°C (10°C/min); Atmosphere: Oxygen (100 ml/min)

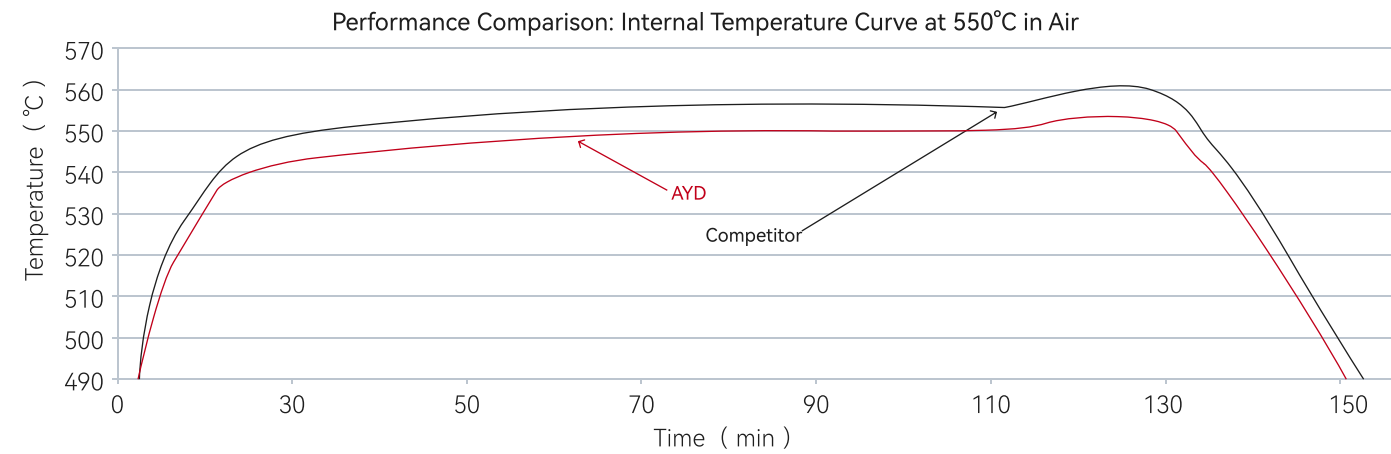

Low Thermal Conductivity

Thermal conductivity reflects the heat transfer capability of carbon fibers, directly impacting their insulation performance in high-temperature environments.

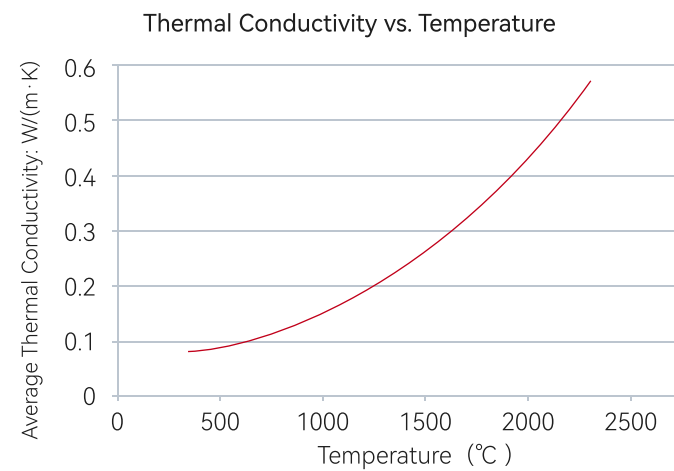

Low Thermal Expansion

Thermal expansion reflects the dimensional stability of carbon fibers under temperature variations, directly affecting their reliability in precision structures and high-temperature applications.

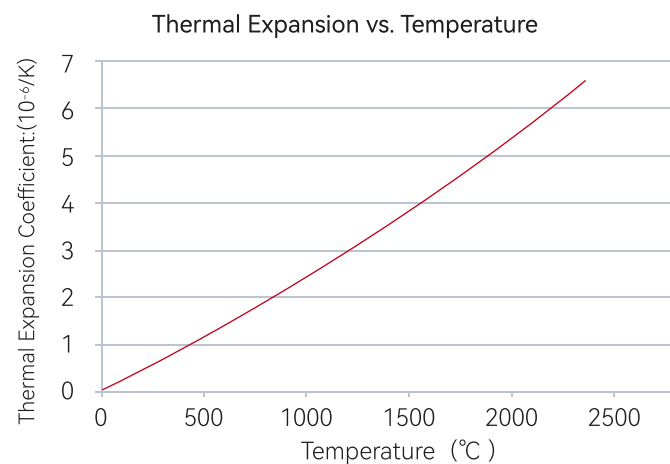

Sample: 50mm thickness, 0.18g/cm³ density. Maintains low thermal conductivity under inert gas protection.

Example of Si-Based Semiconductor Rigid Insulation Solutions (12-inch)

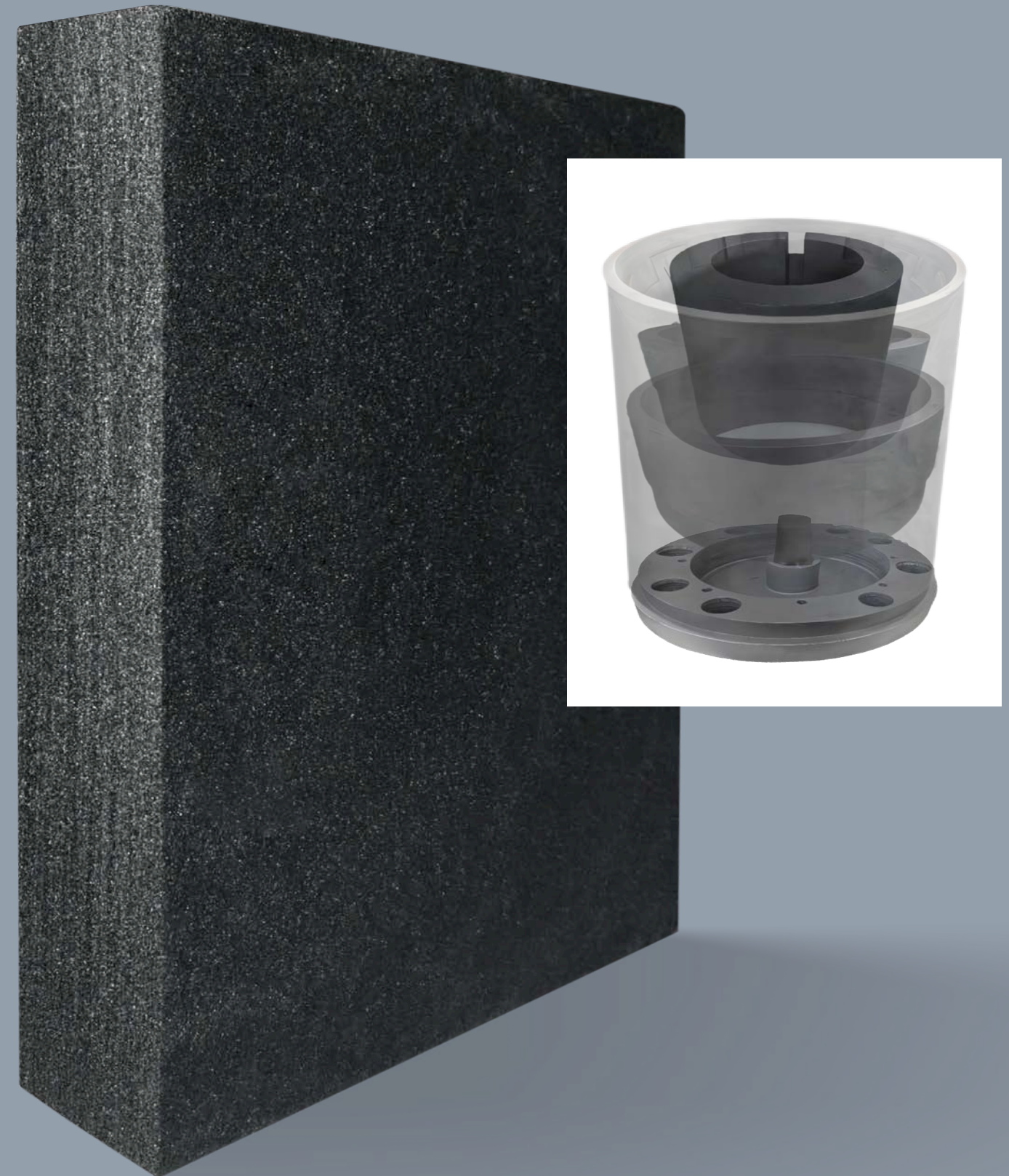



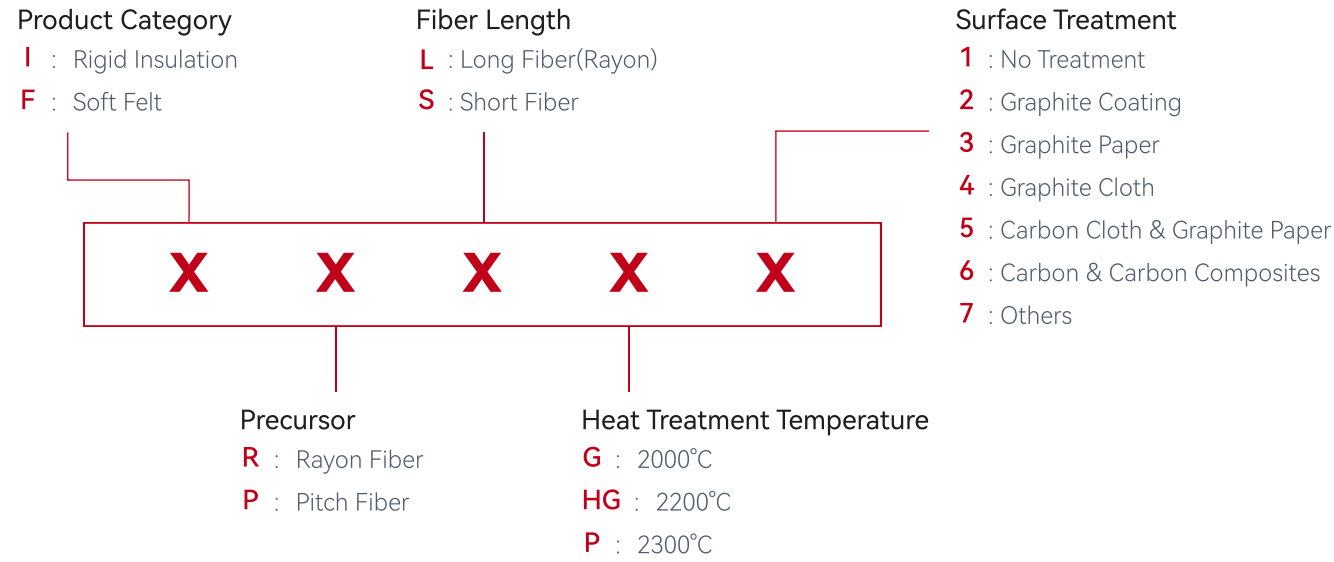

Label Description



Note: This labeling system applies only to Aoyida insulation products.

Example: IPS-HG-2 → High-purity pitch-based short-fiber rigid insulation with graphite coating, treated at 2200°C.

Size Specifications

Type	Maximum Dimensions (mm)
Plate 	IPS: 1700×1700×200T IRL: 1500×1400×50T
Cylinder 	IPS: φ940×560H*80T Wet molding Can be assembled for a larger size IRL : φ1700*1500H*200T
Disc 	IPS: φ1600×200T IRL: φ1500×50T
Customized Parts 	Customized
Soft Felt 	Thickness: 5 or 10 mm Width: 1450mm

Note: φ: Diameter, H: Height, T: Thickness

Surface Treatment



No Treatment

01

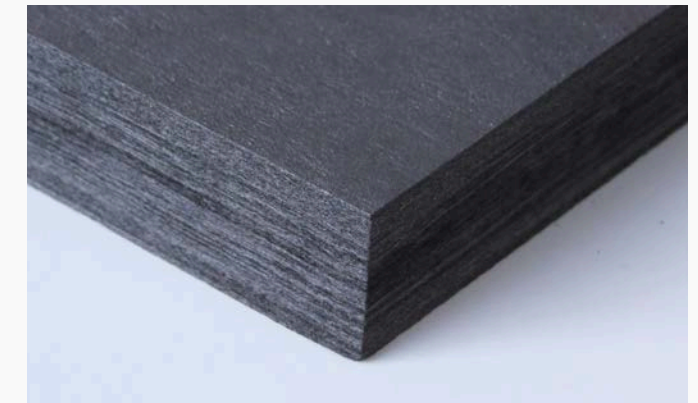

Graphite Coating

02

Prevents fuzzing and dust accumulation
Resistant to airflow erosion



Graphite Paper

03

Prevents fuzzing and dust accumulation
Wear-resistant

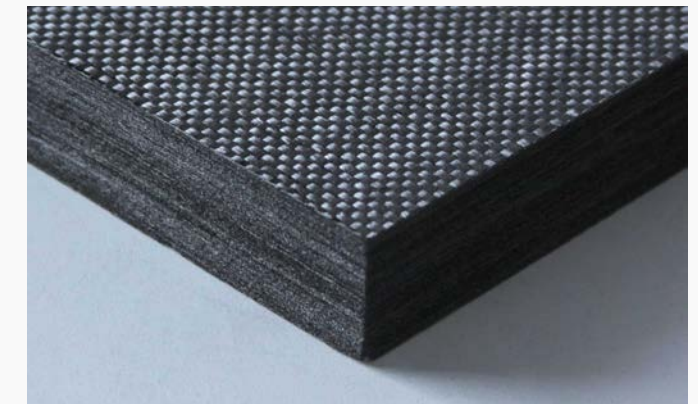

Carbon Cloth

04

Prevents fuzzing and dust accumulation
Wear-resistant and enhances strength

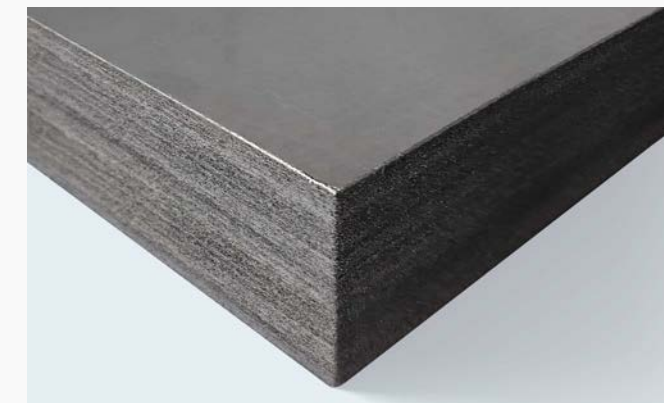

Carbon Cloth + Graphite Paper

05

Prevents fuzzing and dust accumulation
Wear-resistant, resistant to airflow erosion, enhances strength



Carbon & Carbon Composites

06

Prevents fuzzing and dust accumulation
Wear-resistant, resistant to airflow erosion, impact-resistant

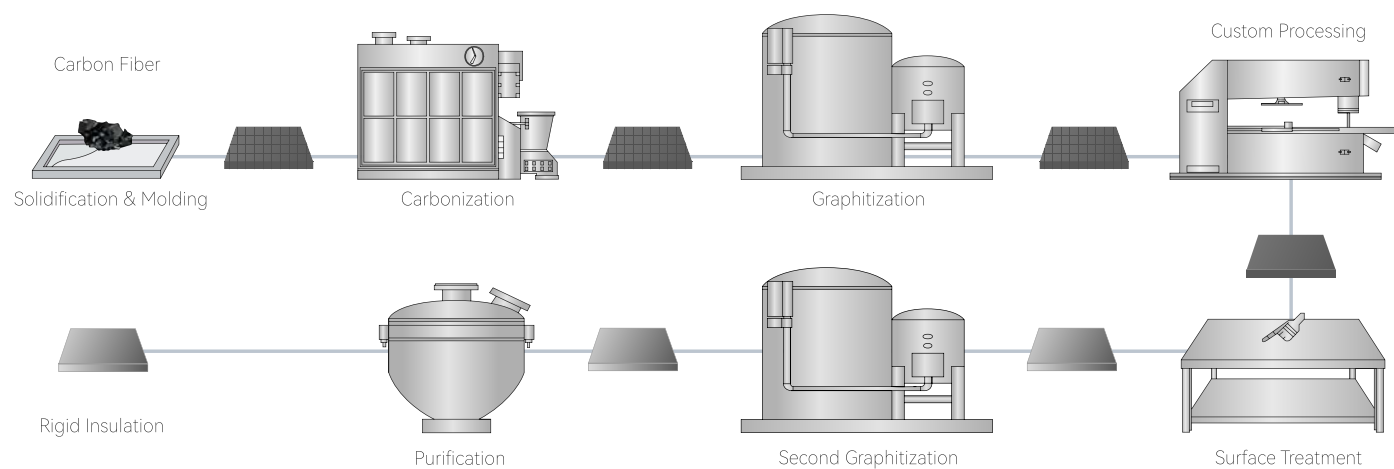

Features

- Advanced high-temperature processing, low ash content, high purity
- Unique short-fiber molding process with precise fiber alignment
- Customizable hot-zone design to meet diverse requirements
- Efficient energy-saving performance

Steady-state Process System

Our insulation products are crafted with precision through a rigorously controlled production process. Strict process management and end-to-end quality assurance ensure unwavering product consistency.

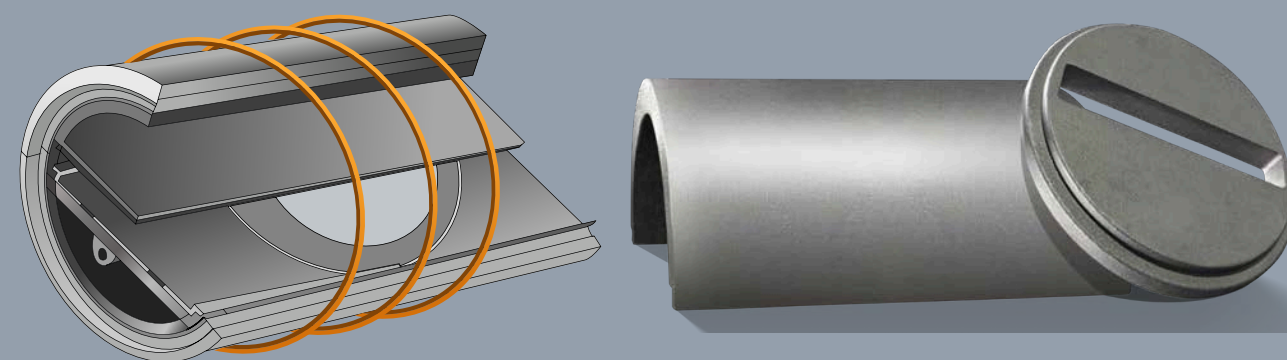
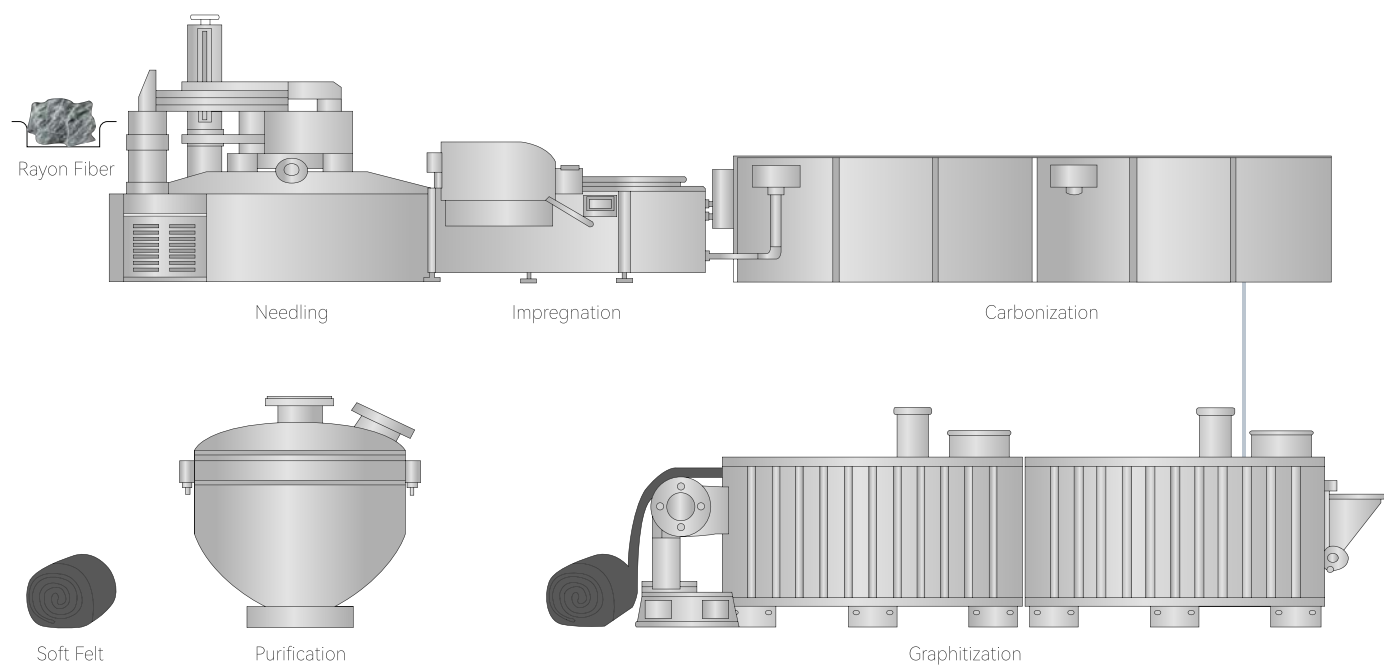
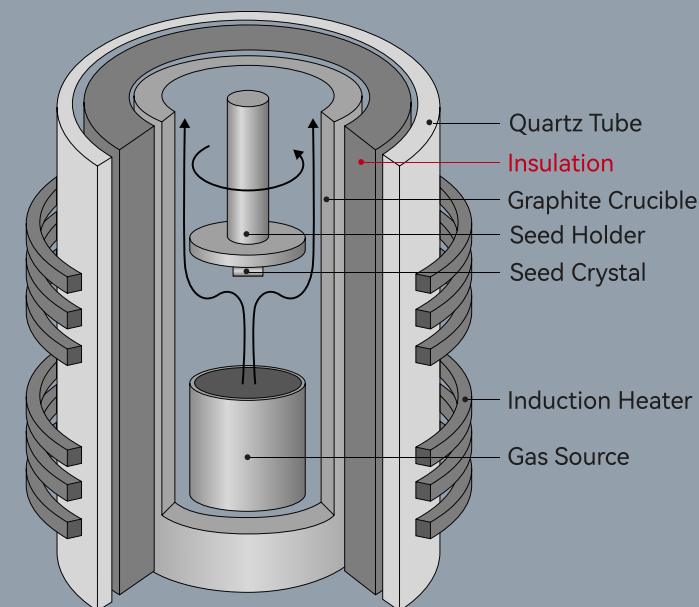
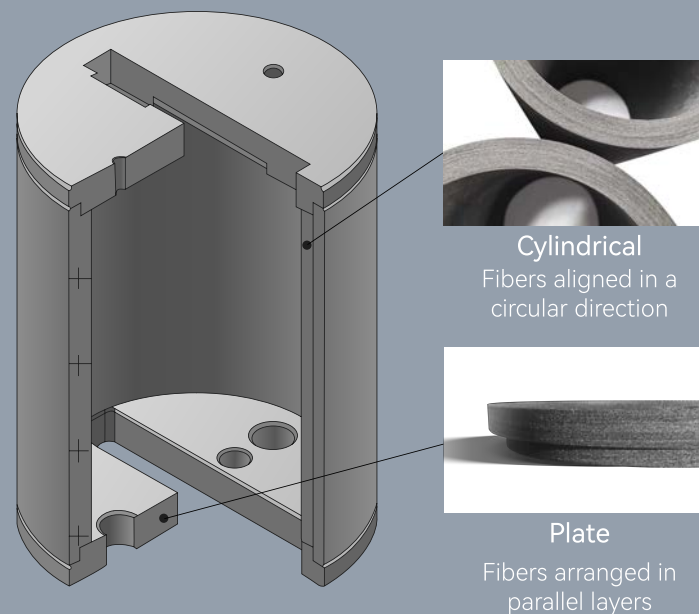

Parameters Rigid Insulation

Pitch-Based Short-Fiber Rigid Insulation (IPS) – Key Physical Properties (Typical Values)

Item	Unit	Standard	High-Temp Graphitized	Purified	Remarks
Density	g/cm ³	0.14-0.25			Can be customized for higher density
Carbon Content	wt%	> 99	> 99.9	> 99.99	
Ash Content	ppm	≤200	≤100	≤20	
Thermal Conductivity	700°C	W/(m·K)	0.129	0.124	Vacuum conditions
	900°C	W/(m·K)	0.167	0.157	
	1300°C	W/(m·K)	0.238	0.312	
	1500°C	W/(m·K)	0.266	0.346	
Thermal Expansion Coefficient	x10 ⁻⁶ /K	<3.5	<3.5		Room Temp-1000°C
		<6.0	<6.0		Room Temp-2000°C
Compressive Strength	MPa	≥0.55	≥0.55		Fracture direction
Flexural Strength	MPa	≥0.69	≥0.69		Fracture direction

Rayon-Based Long-Fiber Rigid Insulation (IRL) – Key Physical Properties (Typical Values)

Item	Unit	Standard	High-Temp Graphitized	Purified	Remarks
Density	g/cm ³	0.14-0.25			Can be customized for higher density
Carbon Content	wt%	> 99	> 99.9	> 99.99	
Ash Content	ppm	≤200	≤100	≤20	
Thermal Conductivity	700°C	W/(m·K)	0.056	0.058	Vacuum conditions
	900°C	W/(m·K)	0.0913	0.102	
	1300°C	W/(m·K)	0.213	0.277	
	1500°C	W/(m·K)	0.251	0.329	
Thermal Expansion Coefficient	x10 ⁻⁶ /K	<3.5	<3.5		Room Temp-1000°C
		<6.0	<6.0		Room Temp-2000°C
Compressive Strength	MPa	≥0.4	≥0.4		Fracture direction
Flexural Strength	MPa	≥0.6	≥0.6		Fracture direction

Rayon-Based Short-Fiber Rigid Insulation (IRS) – Key Physical Properties (Typical Values)

Item	Unit	Standard	High-Temp Graphitized	Purified	Remarks
Density	g/cm ³	0.14-0.25			Can be customized for higher density
Carbon Content	wt%	> 99	> 99.9	> 99.99	
Ash Content	ppm	≤200	≤100	≤20	
Thermal Conductivity	700°C	W/(m·K)	0.082	0.108	Vacuum conditions
	900°C	W/(m·K)	0.116	0.125	
	1300°C	W/(m·K)	0.183	0.270	
	1500°C	W/(m·K)	0.211	0.298	
Thermal Expansion Coefficient	x10 ⁻⁶ /K	<3.5	<3.5		Room Temp-1000°C
		<6.0	<6.0		Room Temp-2000°C
Compressive Strength	MPa	≥0.55	≥0.55		Fracture direction
Flexural Strength	MPa	≥0.69	≥0.69		Fracture direction

CarboniteX Insulation Product Parameter Index – Impurity Content Analysis Table

No.	Element	Standard : AYDR/S	Graphitized: AYD/S-G	Purified: AYDR/S-P
1	B	0.35	0.14	< 0.01
2	Na	0.15	0.08	< 0.05
3	Al	2.5	1.4	0.04
4	Si	9	4.5	1.9
5	P	1.1	0.88	< 0.1
6	K	< 0.1	< 0.1	< 0.1
7	Ca	26	25	< 0.5
8	Ti	0.27	0.23	< 0.05
9	V	0.14	0.11	< 0.01
10	Cr	0.42	0.5	< 0.1
11	Mn	< 0.05	< 0.05	< 0.05
12	Fe	0.96	0.77	0.08
13	Ni	0.05	0.66	< 0.05
14	Cu	< 0.05	< 0.05	< 0.05
15	Zn	< 0.05	< 0.05	< 0.05
Total		40.94	34.27	2.02
Total Impurity(ppm)		≤200	≤100	< 20

Parameters Soft Felt

Features:

- Excellent heat resistance (up to 3000°C)
- Low thermal conductivity-semiconductor level
- Customizable for various applications

Product Parameters – Soft Felt

Item	Unit	Graphitized	Purified	
Processing Temp	°C	2000-2200	2200	
Carbon Content	%	≥99	≥99.99	
Ash Content	ppm	≤500	≤20	
Bulk Density	g/cm ³	0.08 ~ 0.13		
Thermal Conductivity	700°C	W/(m·K)	0.04	0.02
	900°C	W/(m·K)	0.061	0.039
	1300°C	W/(m·K)	0.02-0.08	0.03-0.08
	1500°C	W/(m·K)	0.133	0.198
Compressive Strength	MPa	0.10 ~ 0.16	0.10 ~ 0.16	
Thickness	mm	5/10		
Width	mm	1100-1400		
Length	m	Thickness of 10mm: 20-30m; Thickness of 5mm: 40-50m;		

The data provided is accurate and reliable but does not serve as guaranteed values for specific applications. Products should be used under the professional guidance of AYD.

Method: GDMS

Report Number: P2302244501

Date: 2023-02-26

Sample Name: Soft Felt(Graphitized)

Sample ID: ZDK (2023.2.15) R 1#

Provider: PAT Analysis

Purity: C=99.99911%

TMI (Total Metal Impurities): 8.93 ppmwt

Example: GDMS Data for Soft Felt Product Parameters

Element	Content	Element	Content
Li	< 0.05	Ag	< 0.05
Be	< 0.05	Cd	< 0.1
B	0.03	In	Auxiliary Electrode
C	Main Component	Sn	< 1
F	2.3	Sb	< 0.05
Na	< 0.05	Te	< 0.05
Mg	0.19	I	< 100
Al	0.07	Cs	< 0.05
Si	3.2	Ba	< 0.1
P	< 0.1	La	< 50
S	1.3	Ce	< 0.5
Cl	1.7	Pr	< 0.1
K	< 0.1	Nd	< 0.05
Ca	< 0.5	Sm	< 0.05
Sc	< 0.05	Eu	< 0.05
Ti	0.07	Gd	< 0.05
V	< 0.01	Tb	< 0.05
Cr	< 0.1	Dy	< 0.05
Mn	< 0.05	Ho	< 0.05
Fe	0.07	Er	< 0.05
Co	< 0.05	Tm	< 0.05
Ni	< 0.05	Yb	< 0.05
Cu	< 0.05	Lu	< 0.05
Zn	< 0.05	Hf	< 0.05
Ga	< 0.05	Ta	< 5
Ge	< 0.1	W	< 0.05
As	< 0.1	Re	< 0.05
Se	< 0.1	Os	< 0.05
Br	< 0.1	Ir	< 0.05
Rb	< 0.1	Pt	< 0.1
Sr	< 0.1	Au	< 0.1
Y	< 0.05	Hg	< 0.5
Zr	< 0.05	Tl	< 0.05
Nb	< 0.1	Pb	< 0.5
Mo	< 0.05	Bi	< 0.05
Ru	< 0.05	Th	< 0.01
Rh	< 0.05	u	< 0.01
Rd	< 0.05		

Unit: ppm wt

Soft Felt
Thermal Conductivity vs. Temperature

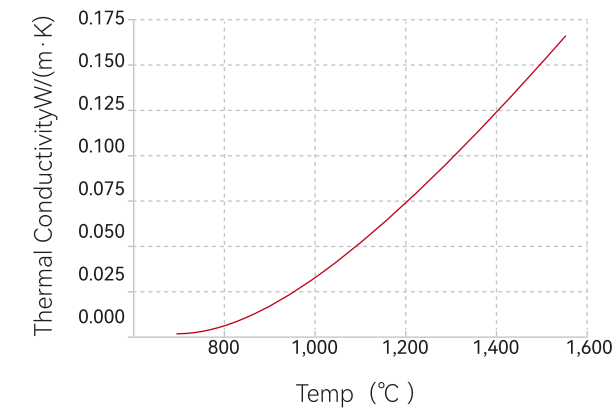

Packaging & Transportation

We offer comprehensive packing solutions, including:

- Semiconductor-grade cleanroom
- Vacuum sealing
- Shockproof & waterproof protection
- Anti-counterfeit labeling



Inner Packaging Methods

Soft Felt	Neatly rolled packaging; Individually vacuum-sealed (for purified products); Wrapped with plastic film and bubble wrap;
Rigid Insulation	Individually vacuum-sealed (for purified products); Stacked neatly per unit; Wrapped with plastic film and secured with special adhesive tape;

Outer Packaging Methods

Main Packaging	Custom cardboard boxes; Custom wooden crates;
Accessories	Polyethylene bubble wrap; EPE sheets; EPE boards; Waterproof plastic film;
Note	International export packaging can be customized upon request;

Cardboard Box

Standard Sizes:

- 900*600*600
- 1000*1000*600
- 1150*600*600/1150*550*550
- 1350*600*600/1350*550*550
- 1500*600*600/1500*550*550

Standard Sizes:

- Can be tailored to specific packaging needs.

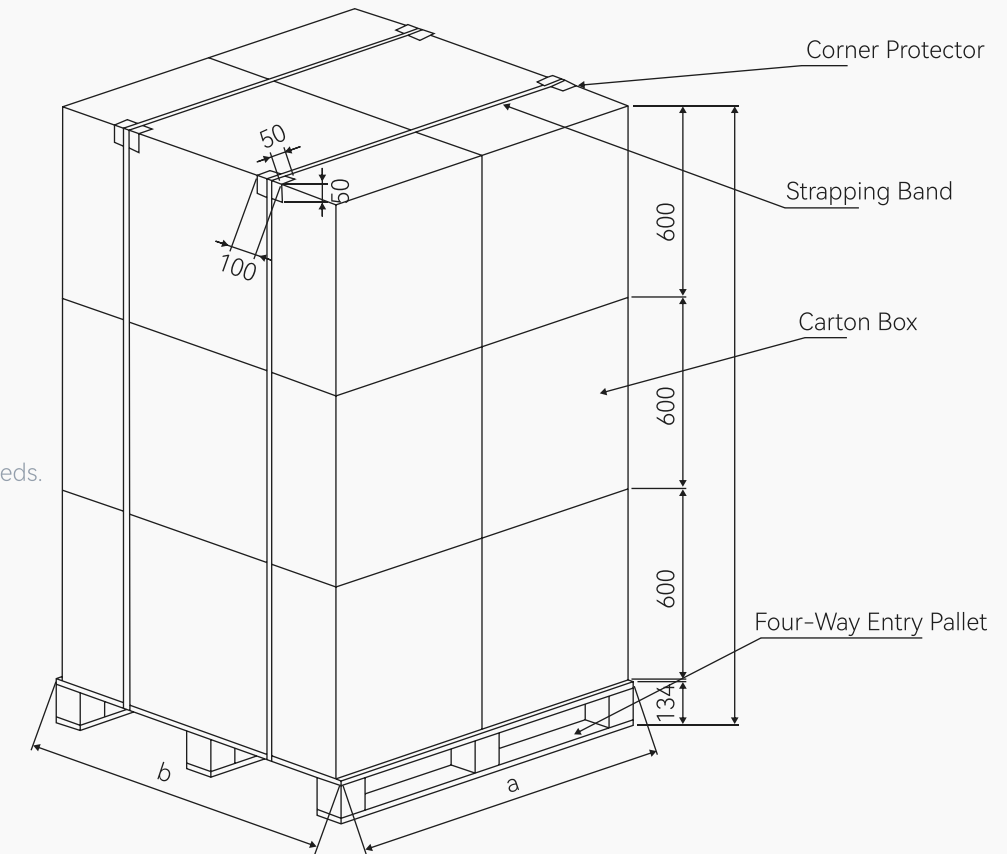

Wooden Crate

Material

Plywood, multilayer board, metal fittings

Specifications

Wooden crates can be fully customized based on transportation vehicles and shipping methods.

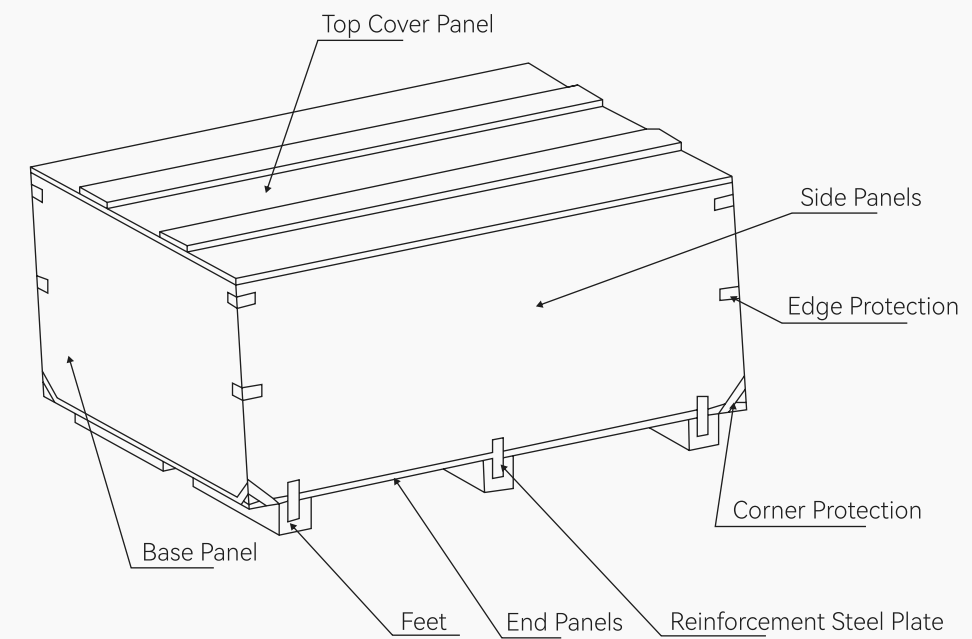

Transportation

Land Transport, Air Freight, Containerized Sea Freight